

STROJNA OBRADA

Gibanja alata kod strojne obrade tokarenjem, bušenjem, glodanjem, blanjanja i brušenja

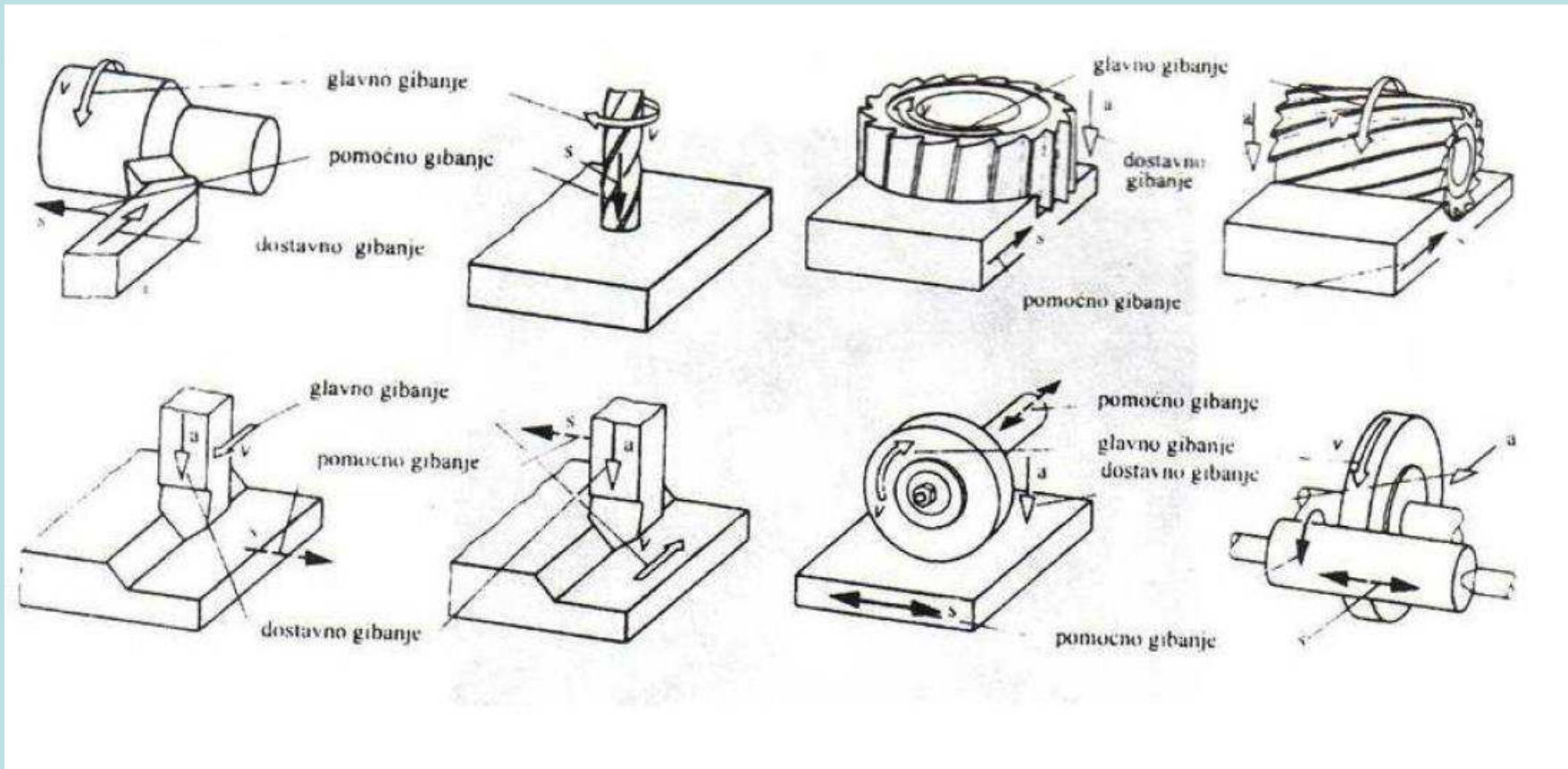

Tokarenje

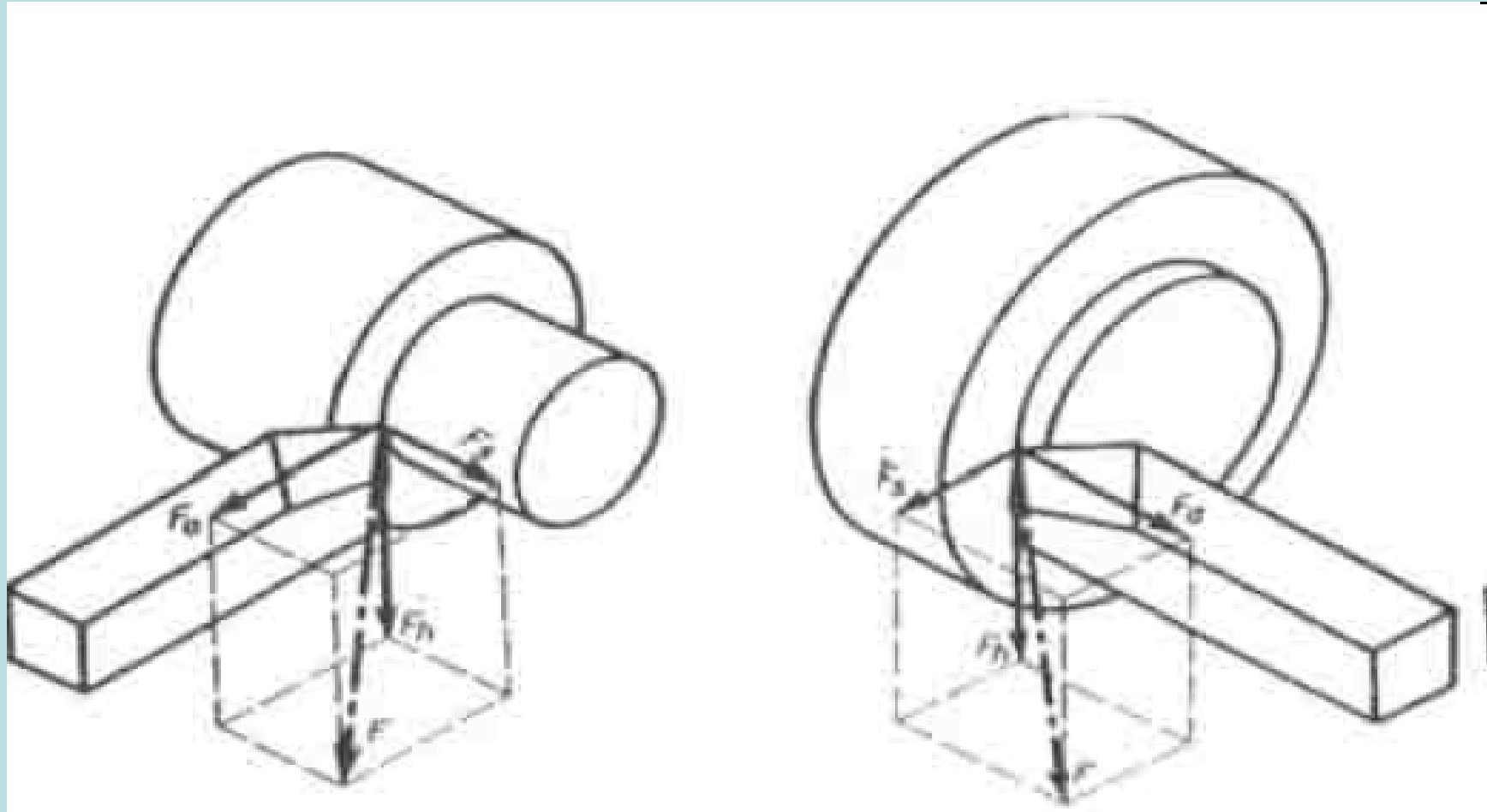

Čeono glodanje

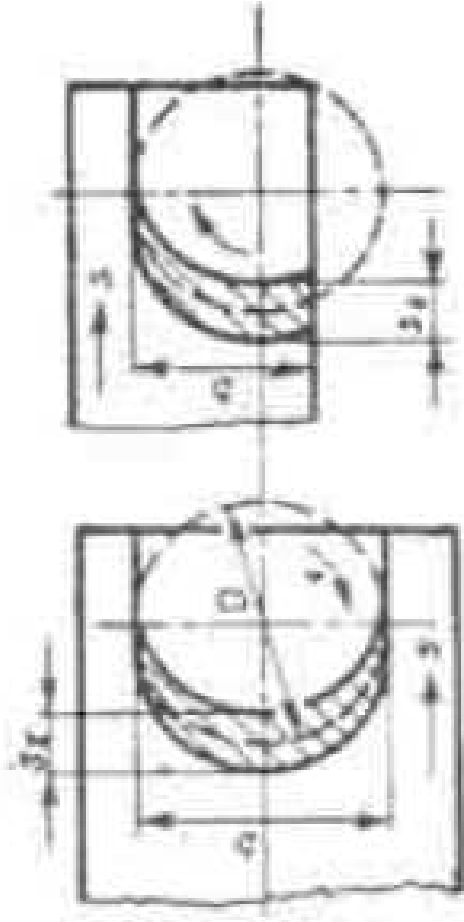
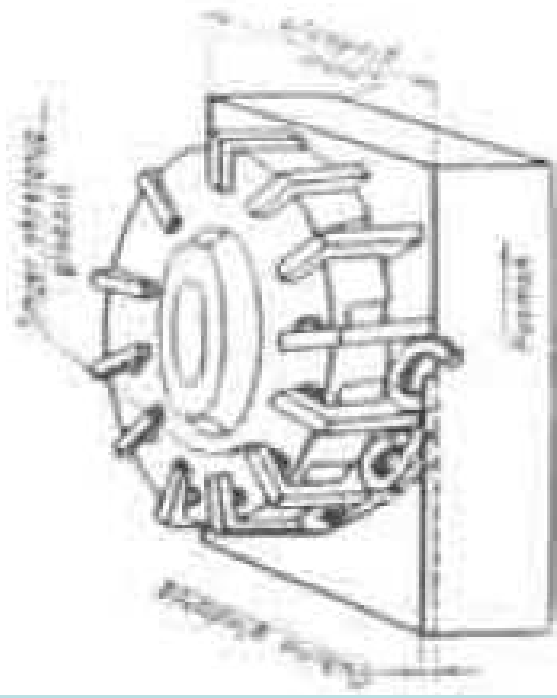

Obodno glodanje

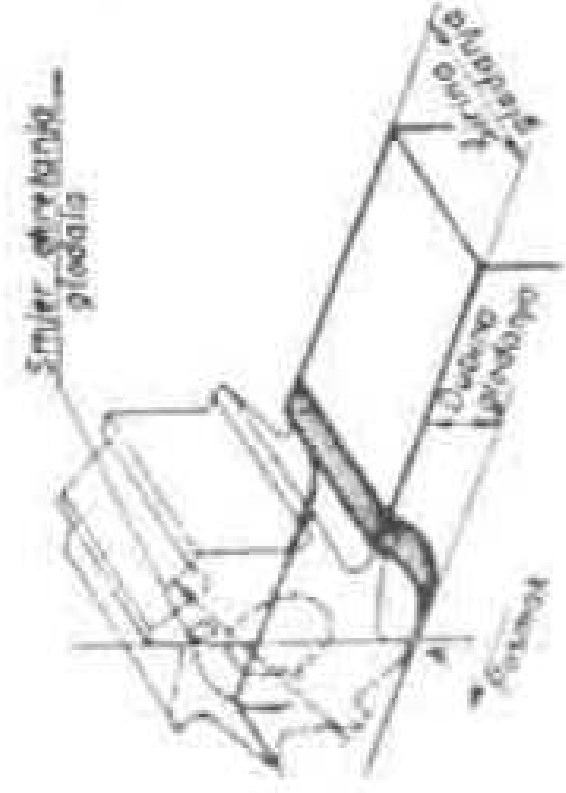
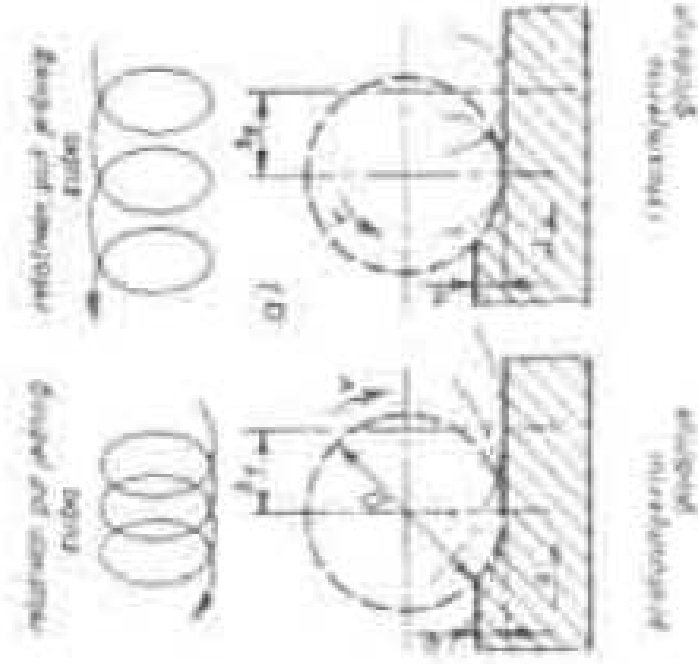

Izvedbe glodala



Blanjanje

- • Podjela postupka
- – Dugohodno
- • Obradak, glavno gibanje
- • Alat, pomocno gibanje
- – Kratkohodno
- • Alat, glavno gibanje
- • Obradak, pomocno gibanje
- • Glavno gibanje je pravocrtno
- • Proces rezanja periodican
- • Radni i jalovi hod

Postupak dubljenja blanjalicom

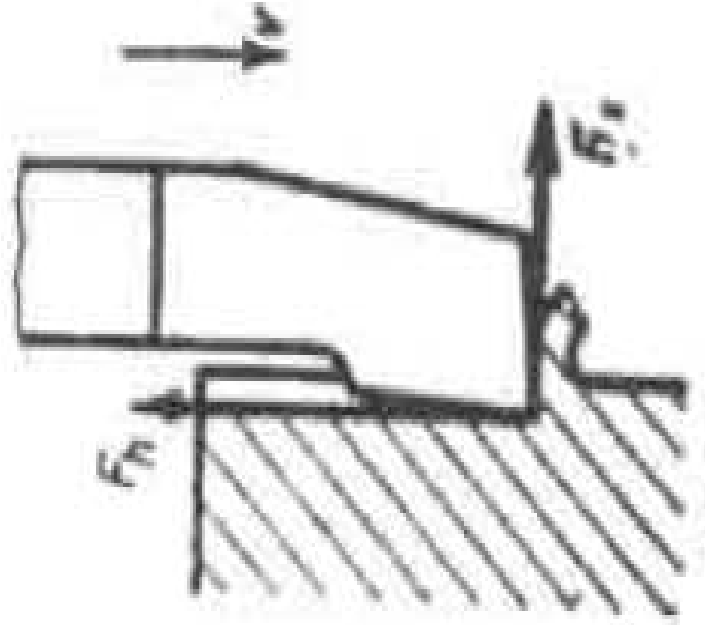

Opis rada i podjela postupaka

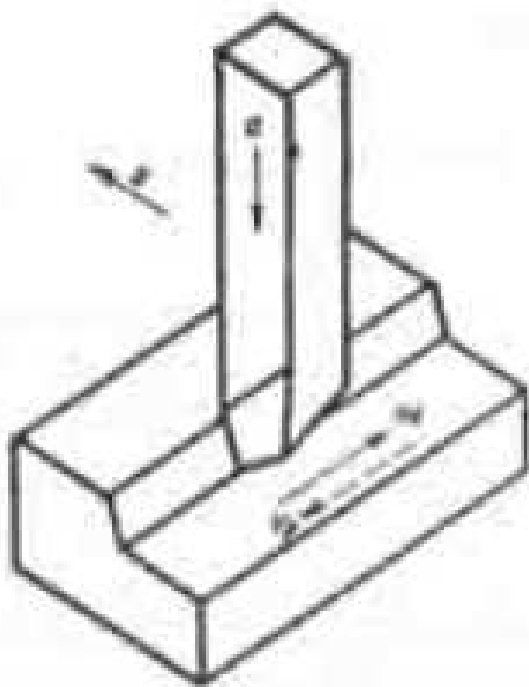

Dugohodno
blanjanje

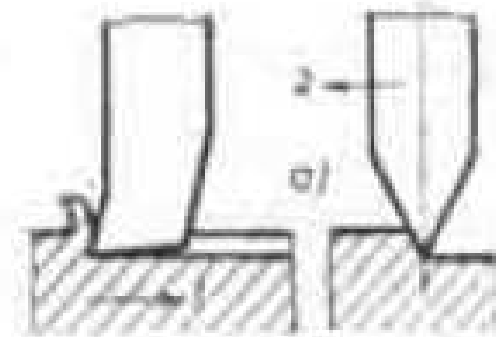

Kratkohodno
blanjanje

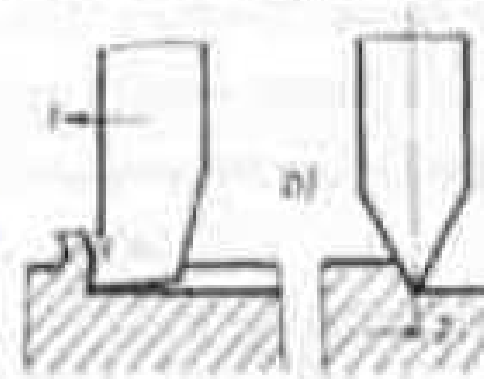

Bušenje – osnovne brzine

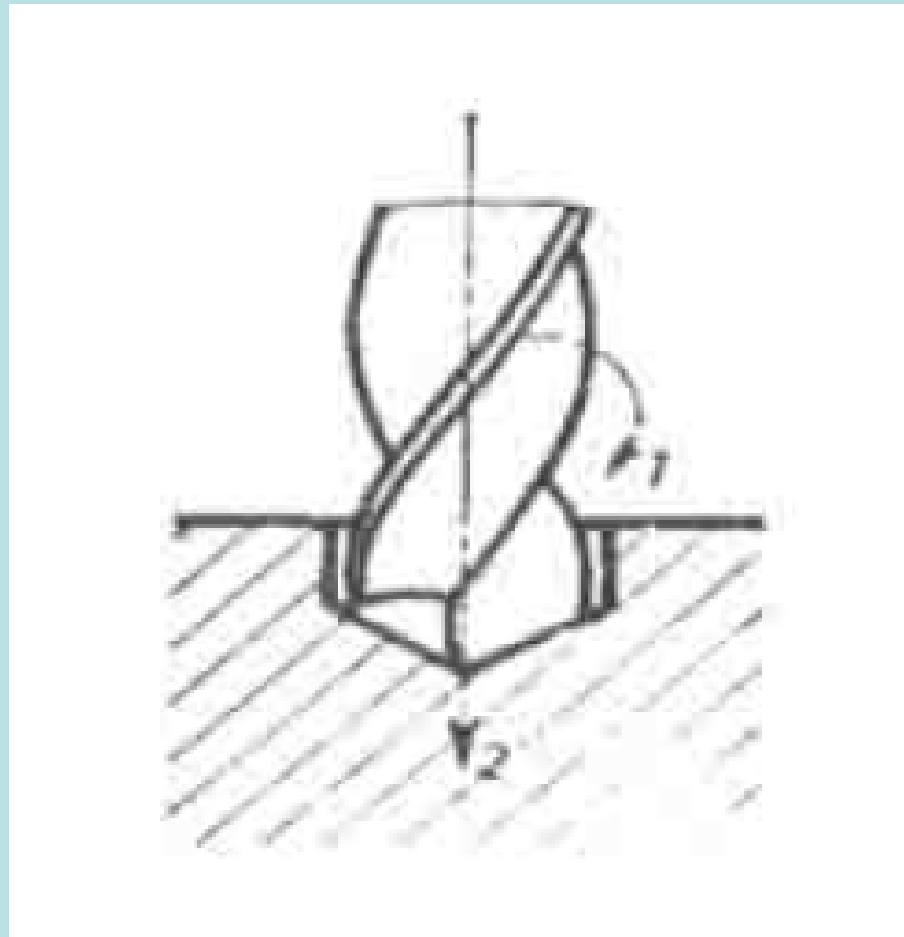

Sile kod operacije bušenja

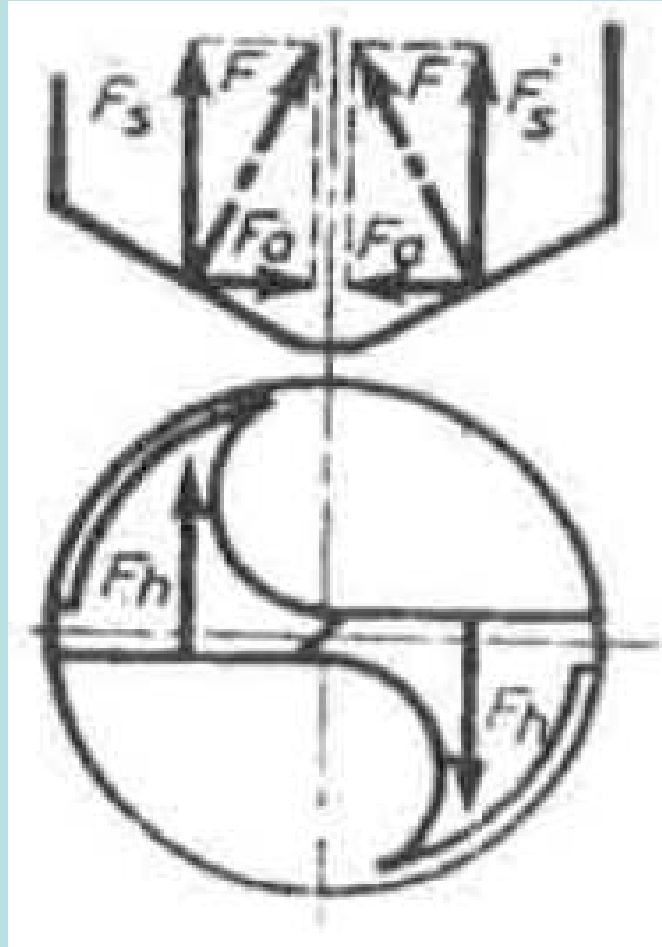

$$F_h = A_1 * f_s$$

Gdje je:

F_h - sila rezanja

A_1 - presjek strugotine na jednoj oštrici

f_s - specifična sila rezanja

Obrtni moment ?

Brušenje

- Postupak završne obrade s malim presjecima strugotine.
- • Podjela:
 - – Vanjsko kružno brušenje
 - – Unutrašnje kružno brušenje
 - – Ravno ili plansko brušenje
 - – Profilno brušenje

Brušenje - uzdužno

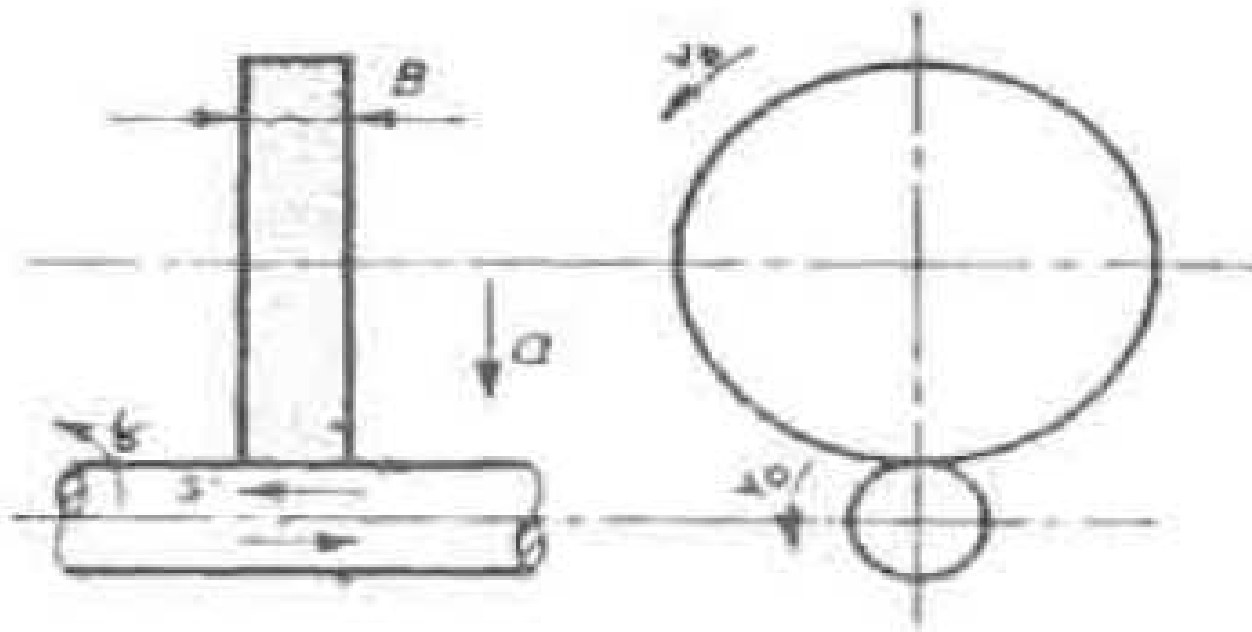

Uzdužno

Radijalno

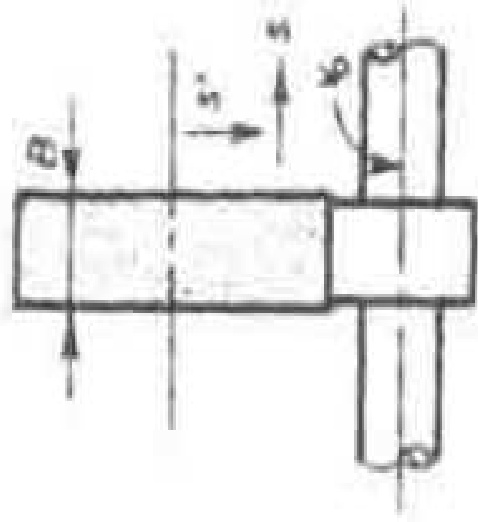

Brušenje bez šiljka

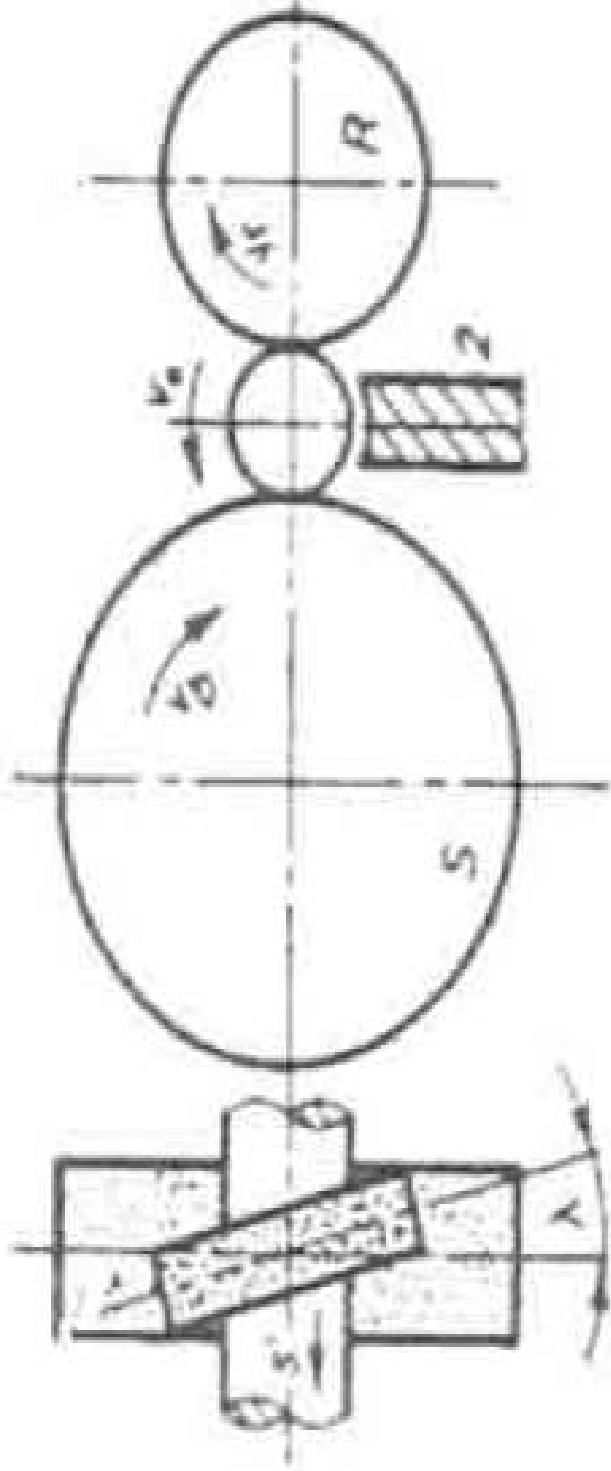

Unutarnje kružno brušenje

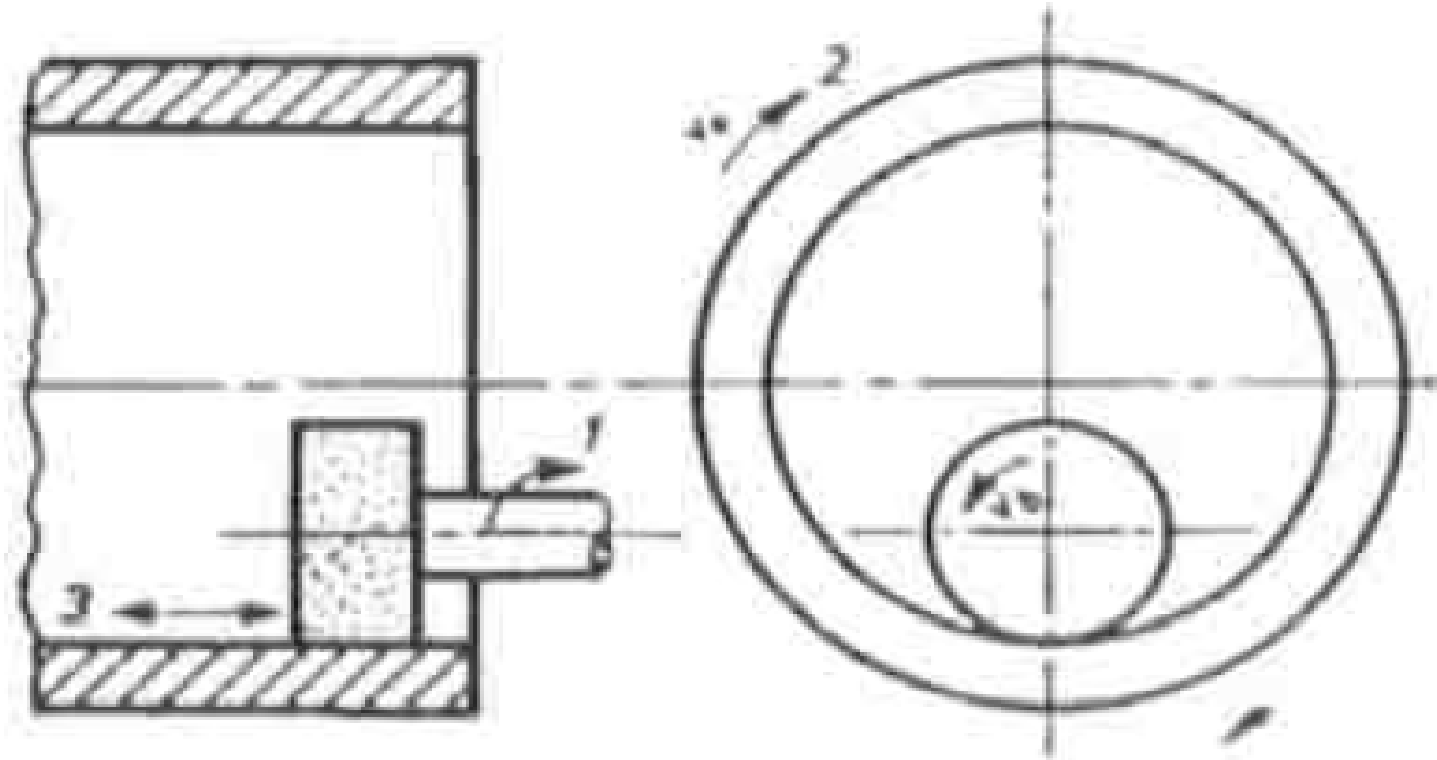

Unutarnje planetarno brušenje

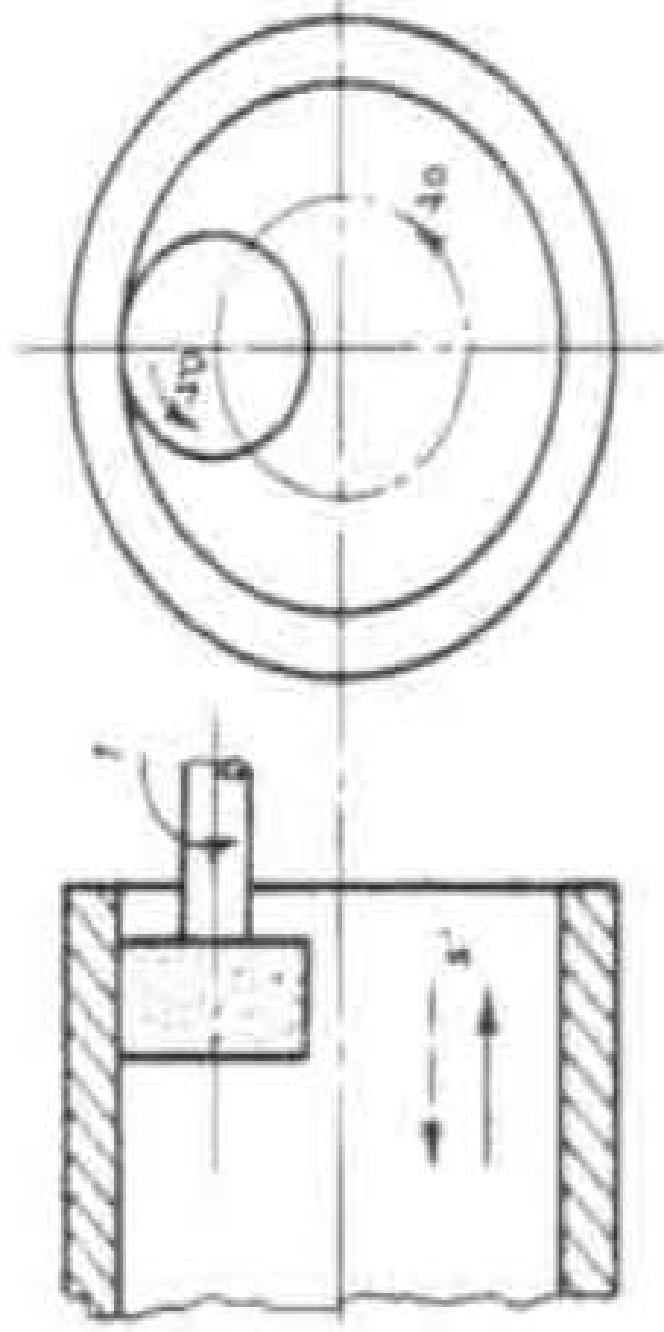

Ravno ili plansko brušenje

